



Media Kit



THE UMBRA STORY

Umbra began in 1979 when Toronto-based friends Les Mandelbaum and Paul Rowan, recognized that there was a need to create modern designs that would be accessible in both price and attitude. They turned a decorating dilemma into an innovative product with the launch of a single window shade appropriately named Umbra (Latin for shade).

Since then Umbra has become a global leader in product design and currently distributes in over 120 countries across the world with additional offices in Europe, the United States, Brazil, and China.

Born out of passion for original design and the desire to create products for every home. Umbra's team of international designers brings thought and creativity into everyday items. Driven by innovation, we pull inspiration from the global marketplace, to push boundaries in our approach to original design.

[Click Here for Brand Video](#)

umbra
© 2023 UMBRA LLC



Les Mandelbaum (left)
and Paul Rowan. 1978



The first Umbra product
- a paper window shade
appropriately named
Umbra (Latin for shade).

ORIGINAL DESIGN IS IN OUR DNA

Everything we produce is original and designed or discovered by our internal team. We are committed to this philosophy and work diligently to protect it.

Unlike much of our competition, Umbra designs into many categories including: Furniture, Photo Display, Wall Display, Hooks, Accessories, Accessory Organization, Kitchen, Bath, Cans, Planters, Mirrors and Window.

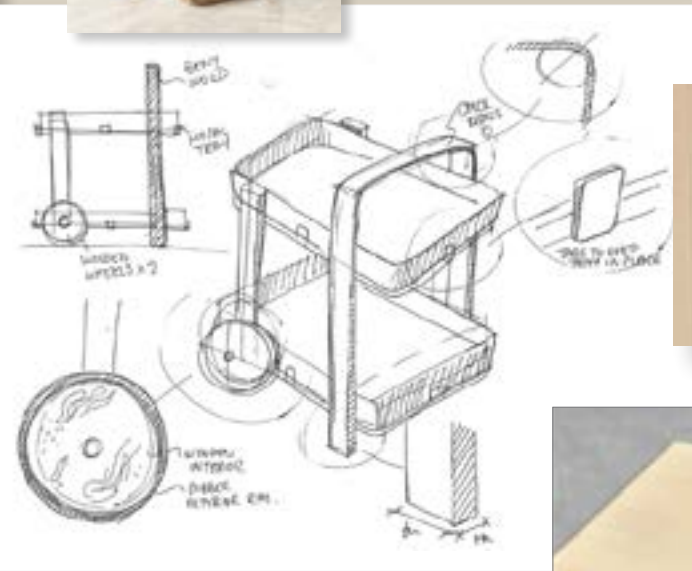

OUR MISSION & VALUES

Umbra creates original products with purpose to enrich your home's personality.



Modern



Casual



Functional



Original

OUR VERY OWN FLAGSHIP RETAIL LAB

In 2007, Umbra opened its flagship concept store located in downtown Toronto which serves a retail environment and also functions as an exhibition and event space.

This uniquely engaging space showcases the brand's entire product collection and welcomes visitors from all over the world who are seeking to connect to our original products and meet our talented group of product designers.

Designed by renowned architecture firm Kohn Shnier it's unique zero-waste facade shifts with the daylight to playfully interact with its environment.



SUSTAINABILITY PLEDGE



Making more responsible choices for the earth begins with thinking about our long-term footprint, that is why Umbra has pledged to design for the planet.

This is our commitment to practice sustainable design as we continue to create modern, original, functional, and thoughtful products that are made to last for years of enjoyment.



ECO FRIENDLY DESIGN



Eco Friendly

Our double-leaf icon is used on specific products and their packaging to identify items that are designed and manufactured in a more sustainable way.

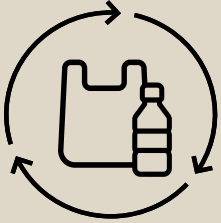

Made with Recycled Plastics

More than 55% of our plastic products now contain recycled material. Additional items are continuously in transition. Our goal is to transition 80% of plastic products to contain recycled material.

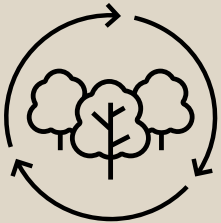

Renewable Wood Sources

More than 65% of our wood products are sourced from fast growing replenishable wood species such as Poplar, Paulownia, Bamboo, Eucalyptus, Rubberwood, and FSC certified wood. Our goal is to transition to using renewable sources in 100% of our products.

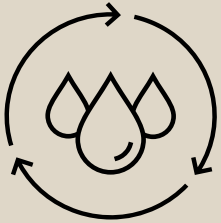

Eco Friendly Finishes

We have transitioned more than 80% of the surface finishing on our metal products, including 100% of our window hardware line, away from harmful electroplating processes toward eco friendly painting and powder coating alternatives. In doing so we are contributing 85% less solid and liquid waste to water systems.

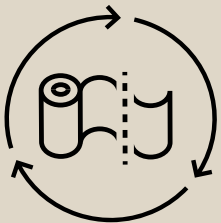

Less Packaging Waste

We have proudly eliminated single use plastic and packing foam from 80% of our packaging by transitioning to recyclable materials. We are always looking for new advancements in packaging technology and design and it is our goal to use recyclable materials in 100% of our packaging.

A NEW LOOK FOR UMBRA PACKAGING

In 2022 we began transitioning from bleached white corrugate boxes to sustainable kraft corrugate and focused on developing OMNI-style (shippable boxes) for the majority of our products. In doing so we've eliminated thousands of pounds of single-use plastic and secondary packaging that previously went to waste.



OMNI (Shippable Box Icon)



Average Annual Waste Reductions

27
TONS

(24,494 kg) of toxic chemicals

9.6
MILLION

FF³ (900 thousand M³) of plastic lamination

53
MILLION

Single-use plastic wrappings, by switching to recyclable tissue paper

8.5
MILLION

Bubble bags, replaced by recyclable paper padding

1.3
MILLION

FF³ (36.8 thousand M³) Styromfoam and EPE foam, by converting to recyclable cardboard

NEW RELEASES



In partnership with smart-home lighting leader Nanoleaf® we're excited to premiere three new smart lamps. These thread and matter-enabled smart colour changing LED Light Bulb that's simple to set up, and easy to control.

- Works with Matter over Thread
- Control via App or Voice
- 16+ Million Colours and Tunable Whites
- Schedules for Automation
- More Customization via Nanoleaf App



Cono Smart Lamp



Cup Smart Lamp



NEW RELEASES

Introducing our Bellwood Pantry Collection, four configurable products that add storage and organization for a multitude of spaces. Like the entire Bellwood collection of products, this family is made with eco-friendly materials and is designed to last.

Lazy Susan

This hardworking organizer keeps items close at hand.



Packet Organizer

Keeps all your treats neat and tidy in one place.



Stackable Bins

Build your dream pantry with these organizational heroes.



Spice Rack

If you wanna be in my cupboard you gotta get this my friends.



umbra

© 2023 UMBRA LLC



A BATHING APE® × UMBRA

We're excited to announce the limited edition A Bathing Ape® x Umbra design collaboration. This exclusive product release features Umbra's Woodrow Can (\$85 CDN) printed with the iconic ape head, available in three color variations - Espresso, White and Natural, along with a 18" mirror silk-screened with BAPE® decal (\$239 CDN).

The limited release is available for purchase through a raffle hosted on umbra.com. The public is invited to sign up for their chance to purchase this exclusive and limited design collaboration with BAPE®. The raffle winners will be drawn the week of June 26th and will be contacted via email with details to complete their purchase.

This product release marks the second collaboration between A Bathing Ape® & Umbra. A previous release in 2022 included the first release of Umbra x BAPE® Woodrow Can and Storage Stool. Umbra was born out of passion for original design and the desire to create products for every home. Umbra's team of international designers bring thought and creativity into everyday items. Driven by innovation, we pull inspiration from the global marketplace, in order to push boundaries in our approach to original design.

[Watch Video](#)

umbra

© 2023 UMBRA LLC



AS SEEN IN

We're proud to say that Umbra and its wide variety of original works were featured in numerous publications worldwide. From print to digital content we're delighted that our design ethos and products are celebrated around the globe.

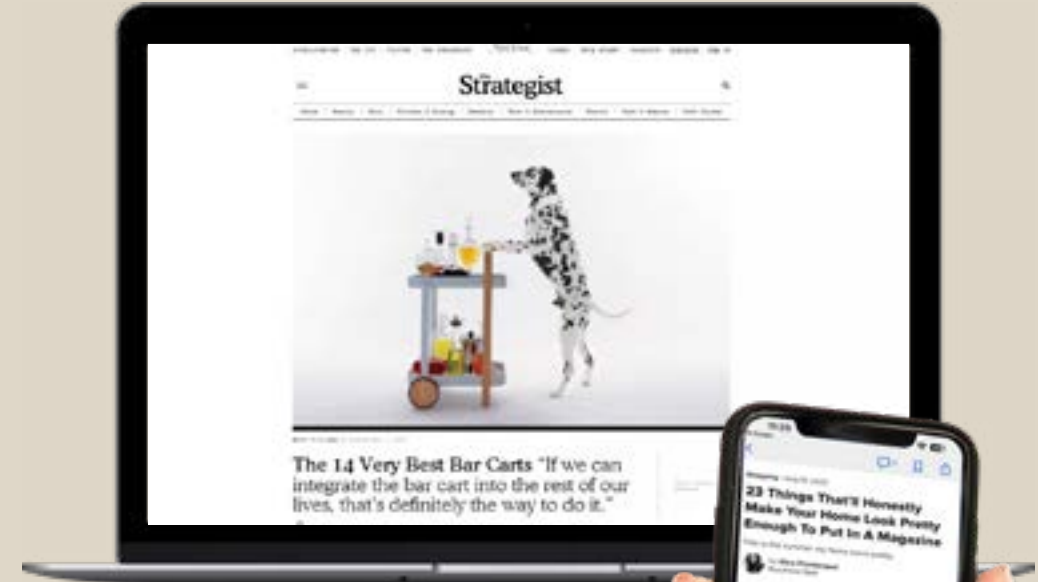

Featured
in over
400
Publications



GLOBAL SUPPORT CENTRE

CANADA | Umbra Ltd.

40 Emblem Court
Toronto, ON
M1S 1B1
Canada
T: 416 299 0088
F: 416 299 6168
info@umbra.com
press@umbra.com

INTERNATIONAL OFFICES

USA | Umbra LLC

1705 Broadway
Buffalo, NY, USA 14212
T 1.800.387.5122
F 416.299.6168
info@umbra.com

CHINA | Umbra Sales Office

3rd floor, No.4
Lane 253 Wuyi Road
Changning District
Shanghai, 200050, China
T 86.400 022 1882
info-asia@umbra.com

BRAZIL | Umbra Design Brazil

Rua Frei Caneca 558, Sala 2101
01307-000
São Paulo, Brazil
T 55.11.2476.5629
latam-info@umbra.com

EUROPE | Umbra B.V.

P.J. Oudweg 4
1314 CH Almere, The Netherlands
T 31.36.549.5422
F 31.36.549.5420
eu-info@umbra.com

CHINA | Umbra HK Limited

8F, Block A Jinfengcheng Building
Shennan East Road, Luohu District,
Shenzhen, 518010, China
T 86.755.2591.5933
F 86.755.8213.5621
info-asia@umbra.com

JAPAN | Umbra Japan

EntreX Inc.
2-19-1, BYGS 7S
Shinjuku-ku, Tokyo
160-0022, Japan
webmaster@entrex.co.jp

